

# Operating Instructions

- Translation-

Please store for future use.

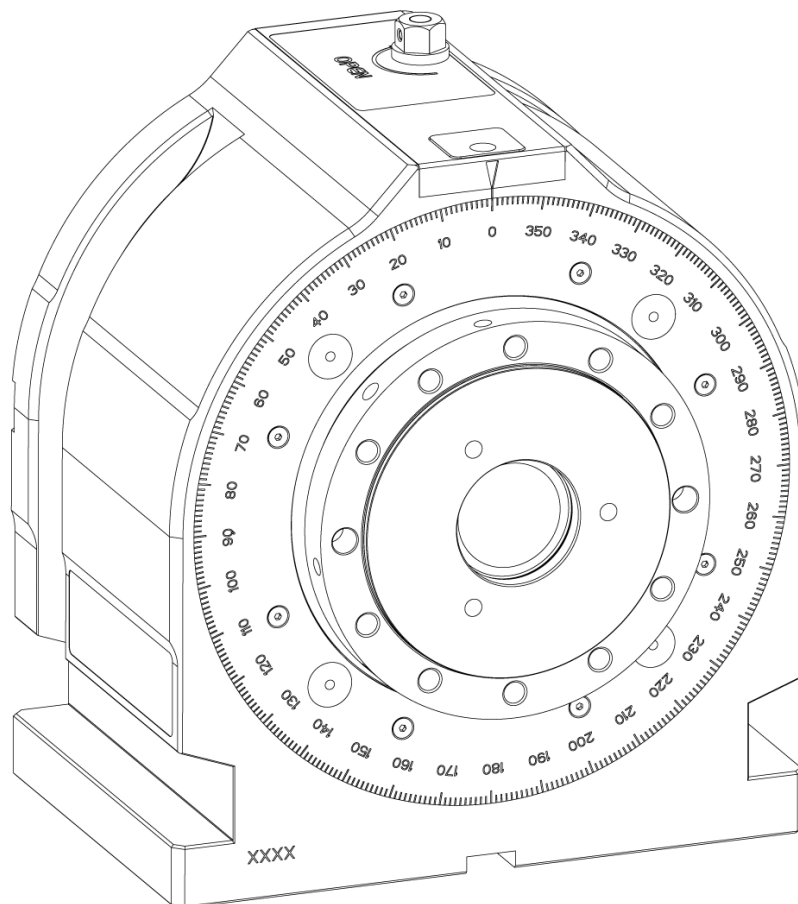

## Rotoklick II

## Manufacturer's address

Haff & Schneider GmbH & Co. OHG  
Obere Wank 2  
87484 Nesselwang  
Germany  
Tel.: +49 8361 / 9218-0  
Fax: +49 8361 / 9218-40

## Formal information on the Operating Instructions

Version: 2, Translation of the original Operating Instructions  
File name: Operating Instructions Rotoklick II  
Creation date: 08.05.2023  
Revision date: 31.01.2024  
Printing date: 07.07.2026

## Purpose of the document

The present Operating Instructions are meant to make the operators of the dividing head Rotoklick II familiar with:

- the operating principle
- the operating method and handling
- the safety instructions
- the maintenance of the device.

## Storage

The Operating Instructions must always be kept in close vicinity of Rotoklick II for later reference. They should always be accessible.

© 2026 Haff & Schneider GmbH & Co. OHG  
Obere Wank 2  
87484 Nesselwang  
Germany

All rights reserved. Reproduction, even in part, is only permitted with the authorization of Haff & Schneider GmbH & Co. OHG.



For this product, further information is available. Scan the QR code or visit <https://haff-schneider.com/support/rotoklick-2/>.

## Contents

<b>1</b>	<b>General notes</b> .....	<b>5</b>
1.1	Observe the notes in the Operating Instructions.....	5
1.2	Warranty and liability.....	5
1.3	Intended use.....	5
1.4	Field of application.....	6
1.5	Foreseeable misuse.....	6
1.6	Nameplate.....	6
1.7	Scope of delivery.....	6
<b>2</b>	<b>Safety</b> .....	<b>7</b>
2.1	Presentation of safety instructions.....	7
2.2	Informal safety measures.....	8
2.3	Personal protective equipment.....	10
2.4	Qualification level.....	11
2.5	Responsibilities for activities.....	12
2.6	Time limits.....	12
2.7	Working area and danger zone.....	13
2.8	Hazardous substances.....	13
<b>3</b>	<b>Description</b> .....	<b>14</b>
<b>4</b>	<b>Technical data</b> .....	<b>15</b>
<b>5</b>	<b>Commissioning</b> .....	<b>16</b>
5.1	Transport.....	18
5.1.1	Transport of dividing head.....	19
5.1.2	Transport of dividing head including optional equipment.....	20
5.2	Attachment in the working area.....	21
5.2.1	Upright attachment.....	21
5.2.2	Flat attachment.....	22
<b>6</b>	<b>Manual indexing</b> .....	<b>23</b>
<b>7</b>	<b>CNC-controlled indexing</b> .....	<b>25</b>
7.1	Indexing tool.....	27
7.1.1	Vertical indexing tool.....	28
7.1.2	Horizontal indexing tool.....	29
7.1.3	Predetermined breaking point on the indexing tool.....	30
7.1.4	Reference point / program zero point for indexing movement.....	31
7.1.5	Approach / unlock.....	32
7.1.6	Indexing movement / rotation.....	33

7.1.7	Lock / retract .....	34
7.2	Use of the angle calculator .....	35
7.2.1	Example 1: Rotary movement from 0° to 90° .....	37
7.2.2	Example 2: Rotary movement from 0° to 120° .....	39
7.3	Programming examples .....	43
7.3.1	Programming examples for DIN-type control units .....	43
7.3.2	Programming example for Heidenhain TNC 355 .....	44
7.3.3	Programming example for Heidenhain TNC 640 .....	45
<b>8</b>	<b>Optional equipment .....</b>	<b>46</b>
8.1	Wedge-shaped clamping elements for radial flange connection .....	48
8.2	Lathe chuck .....	49
8.3	Rocker .....	50
8.4	Traverse .....	51
8.5	Cube .....	52
<b>9</b>	<b>Maintenance .....</b>	<b>53</b>
9.1	Warranty .....	54
9.2	Maintenance .....	54
9.3	Inspection .....	54
<b>10</b>	<b>Decommissioning, storage, disposal .....</b>	<b>55</b>
10.1	Decommissioning .....	55
10.2	Storage .....	55
10.3	Disposal .....	55
<b>11</b>	<b>Annex .....</b>	<b>56</b>
11.1	List of part numbers .....	56
11.2	EU Declaration of Conformity .....	57
11.3	Rotoklick II - Dimension sheet .....	58
11.4	Rotoklick II - Component overview .....	59

# 1 General notes

## 1.1 Observe the notes in the Operating Instructions

For safe handling and trouble-free operation of Rotoklick II, the operating staff must be familiar with the basic safety instructions and safety regulations.

These Operating Instructions include important information for safe and proper operation and handling of Rotoklick II and must be stored at the operation site.

These Operating Instructions and the safety instructions in particular must be complied with by all persons working with Rotoklick II.

The Operating Instructions are regarded as an integral part of the product. When Rotoklick II is transferred or sold, the Operating Instructions must be handed out together with it.

Furthermore, the regulations and instructions for accident prevention applicable at the operation site have to be observed.

## 1.2 Warranty and liability

Principally, our "General Terms and Conditions of Sale" apply.

They have been made available to the operating company since the conclusion of the contract at the latest.

Any warranty or liability claims in the case of personal injury and/or property damage shall be excluded if they are due to one or several of the following causes:

- Improper use
- Use of spare parts, accessories, attachments and special equipment which have not been inspected and approved by the manufacturer
- Improper installation, commissioning, operation and maintenance of Rotoklick II
- Non-observance of the regulations and information on transport, storage, assembly, commissioning, operation, maintenance in the Operating Instructions
- Unauthorized structural modifications to Rotoklick II
- Disasters caused by the impact of foreign objects and force majeure
- Improperly performed repairs



### Information

Opening the device will render the warranty void.

---

## 1.3 Intended use

The dividing head is solely intended to provide a CNC machine with an additional axis. Rotoklick II enables all-around machining using a lathe chuck without and with tailstock, rocker clamping with counter holders or the use as multiple clamping device. Indexing is performed manually or automatically by the CNC machine.

## 1.4 Field of application

The use of Rotoklick II is only allowed in industrial or professional environments.

Rotoklick II has been designed only for indoor applications.

The mounting surface must be level and clean.

Ambient temperature at the installation site: +5 to +40 °C

Maximum humidity: Max. 60%, without condensation

## 1.5 Foreseeable misuse

The following conditions are classified as **misuse**:

- Use in private environment
- Outdoor use
- Use in explosive areas
- Use after the device and its protective devices have been modified or converted in an unauthorized manner, without complying with the applicable regulations
- Use with safety and protective devices being bypassed or disabled
- Use with improper accessories or with peripheral devices linked with the machine
- Use of the device with tools, parameters and equipment other than those specified by the manufacturer

The following conditions are classified as **wrongful use**:

- Use outside the defined operating parameters
- Use of a device that has been modified in a manner not authorized by the manufacturer

## 1.6 Nameplate

The nameplate is located on the side of the housing.

Bezeichnung <i>name</i>	<input type="text"/>		
Artikelnummer <i>article number</i>	<input type="text"/>	Baujahr <i>year built</i>	<input type="text"/>
Seriennummer <i>serial number</i>	<input type="text"/>	Gewicht <i>weight</i>	<input type="text"/>
Max. Haltemoment <i>max. holding moment</i>	<input type="text"/>		

Haff & Schneider  
1956

Haff & Schneider GmbH & Co. OHG  
Obere Wank 2  
87484 Nesselwang  
Germany

CE

Made in Germany

## 1.7 Scope of delivery

- Ring spanner
- Dividing head
- Operating Instructions

## 2 Safety

### 2.1 Presentation of safety instructions

The safety instructions in these Operating Instructions are classified into general information, notes, cautions, warnings and dangers. The safety instructions used in these Operating Instructions are shown below by way of example to illustrate the types of the safety instructions and the respective hazard levels.



#### **DANGER**

##### **Danger**

Identifies an imminent hazard.

→ Failure to avoid this situation will result in death or most severe injury.

---



#### **WARNING**

##### **Warning**

Identifies a potentially hazardous situation.

→ Failure to avoid this situation will result in death or severe injury.

---



#### **CAUTION**

##### **Caution**

Identifies a potentially hazardous situation.

→ Failure to avoid this situation can result in minor or moderate injury.

---



#### **NOTE**

##### **Note**

Identifies a potentially damaging situation.

→ Failure to avoid this situation can result in damage to the product or other property damage.

---



##### **Information**

This symbol includes user tips and particularly useful information.

---

## 2.2 Informal safety measures

In addition to the Operating Instructions, the general local rules and regulations for accident prevention and environmental protection must be provided and complied with.

Furthermore, the safety measures required for the machine in which Rotoklick II is incorporated must be observed. Always wear the personal protective equipment required for this machine.



### DANGER



#### Hazard generated by tipping of the device or of components

Loss of stability can cause the device or elevated components to tip over.

- Supporting structures must have been designed to withstand static and dynamic loads.
- Supporting structures must have been dimensioned and designed in a way that tipping over of the fastened device is positively prevented.



### WARNING



#### Hazard generated by misconduct

Faulty operation or misconduct can cause accidents, property damage and have long-term effects.

- The device may be installed and commissioned only by properly instructed and qualified staff.
- Observe the safety instructions in the Operating Instructions.



### CAUTION



#### Hazard generated by parts becoming loose

Parts becoming loose or flying around due to elastic elements can cause minor, reversible injury.

- Secure the workpiece with appropriate safeguarding devices and sufficient torque.



### CAUTION



#### Slipping, tripping or falling hazard

Workpieces or machine components lying around or spills can cause people to slip, trip or fall. This can lead to minor or moderate injury.

- After their use, always store tools and machine components at the locations provided for this purpose.
- Do not leave tools in the machine.
- Make sure the floor is clean.



**CAUTION**



**Hazard generated by poor lighting**

The risk of accidents increases with poor lighting.

- Select a lighting system of appropriate illuminance for the surrounding area.
- Ensure unobstructed view of the machining process.

**NOTE**







**Hazard generated by overloading**

Machine and device overloading can cause damage.



- Observe the valid load limits and characteristic values of machine and device.

## 2.3 Personal protective equipment

Pictogram	Description
 A blue circular pictogram showing a white boot, representing protective footwear.	<b>Wear protective footwear</b> <ul style="list-style-type: none"><li>→ Protective footwear will protect the feet against crushing, falling parts and slipping on slippery surfaces.</li></ul>
 A blue circular pictogram showing two white gloves, representing protective gloves.	<b>Wear protective gloves</b> <ul style="list-style-type: none"><li>→ Protective gloves are used to protect the hands against hazardous substances, friction, graze, puncture or deep cuts as well as against contact with hot surfaces.</li></ul>
 A blue circular pictogram showing a white protective suit, representing protective clothing.	<b>Wear protective clothing</b> <ul style="list-style-type: none"><li>→ Protective clothing is defined as tight-fitting working clothing that protects against hazardous substances and other hazards.</li></ul>
 A blue circular pictogram showing a white face wearing safety glasses, representing eye protection.	<b>Wear eye protection</b> <ul style="list-style-type: none"><li>→ Eye protection prevents substances hazardous to health and foreign matter from getting into the eyes.</li></ul>

## 2.4 Qualification level

All maintenance, inspection and repair work may only be performed by persons complying with the qualification levels of the manufacturer.

<b>Qualification level</b> 	<b>Definition of the qualification level</b>
<b>Instructed operator</b> 	<p>The operator must be instructed by the operating company in the tasks assigned to him or her and in the hazards that may occur in case of inappropriate behavior. Tasks exceeding the operation under normal operating conditions may not be carried out by the operator unless they are described in the Operating Instructions and unless they have been expressly assigned to him or her by the operating company.</p> <p>(In accordance with the BetrSichV (German Ordinance on Industrial Safety and Health), section 9, subsection 2, No. 2)</p>
<b>Qualified mechanical staff</b> 	<p>Based on professional training, expertise and experience as well as on the knowledge of the pertinent standards and regulations, qualified staff are able to carry out the work assigned to them and to autonomously identify possible risks and avoid hazards.</p> <p>(In accordance with the BetrSichV (German Ordinance on Industrial Safety and Health), section 9, subsection 2, No. 1)</p>

## 2.5 Responsibilities for activities

Activity	Qualification level
Transport	Non-specialists
Assembly, installation	Qualified staff
Commissioning	Qualified staff
Use/operation	Instructed operator
Repair and maintenance	Qualified staff
Decommissioning, disassembly, disposal	Qualified staff

## 2.6 Time limits

Specification	Description
Maximum uninterrupted operating time	Multiple-shift 24-hours operation, 7 days a week
Expected service life	<ul style="list-style-type: none"> <li>• Expected service life, taking the intended use into account: 6 years → Then revision (if necessary, general overhaul) by the manufacturing company or a specialist company</li> <li>• Device may be operated only within the defined time limits for operation (operating time, shift sequence, maintenance specifications).</li> </ul>
Period / frequency of stay of people in the danger zone	Long / often
Maintenance intervals	Maintenance-free

## 2.7 Working area and danger zone

The danger zone must be entered for the following tasks:

- Operation of machine and device (manual indexing)
- Material feeding
- Machine set-up
- Installation of accessories
- Cleaning
- Troubleshooting
- Installation and removal of the dividing head

To be observed as well:

Specification	Description
Access to the machine	From the front through the machine guard door in case of CNC machines Possible from all sides in case of machine tools
Space required for operation	At least 1.0 m in front of the machine
Space required for maintenance	At least 1.0 m in front of the machine
Working area	On CNC machines, the entire danger zone is secured by an enclosure that comprises a guard door.

## 2.8 Hazardous substances

The following hazardous substances may exist. The operating company is responsible for the compliance with the material safety data sheets as well as for the performance and supervision of the measures required to avoid harmful effects.

Hazardous substance	Type of risk	Material safety data sheet (MSDS)
Grease	<ul style="list-style-type: none"> <li>• Can cause <b>irritation of the respiratory system</b></li> <li>• Can cause <b>skin irritation</b> in case of repeated contact</li> <li>• Can cause <b>eye irritation</b></li> </ul>	Manufacturer / supplier

→ When handling grease, always wear personal protective equipment.

### 3 Description

Rotoklick II is a dividing head that provides the machine with an additional axis. Irrespective of the machine at hand, it can be mounted on any standardized machine table. With this dividing head, indexing can be realized both manually and under CNC control.

For manual indexing, Rotoklick II is unclamped by loosening the nut at its top using a ring spanner (1). After unclamping, the hollow spindle can be moved by hand. The increments can be read from the scale (3).

At the top of Rotoklick II, there is a reference spot (2) for probing.

With CNC-controlled indexing, Rotoklick II is unclamped by pushing the indexing tool into the pick-up points (4), followed by the indexing movement around the zero point.

The front and the sides of the spindle (5) are provided with various tapped holes (7) and fittings that can be used to mount further optional devices.

Rotoklick II is mounted and aligned on the table by means of the T-slots (9) and a shallow slot at the bottom side (8).

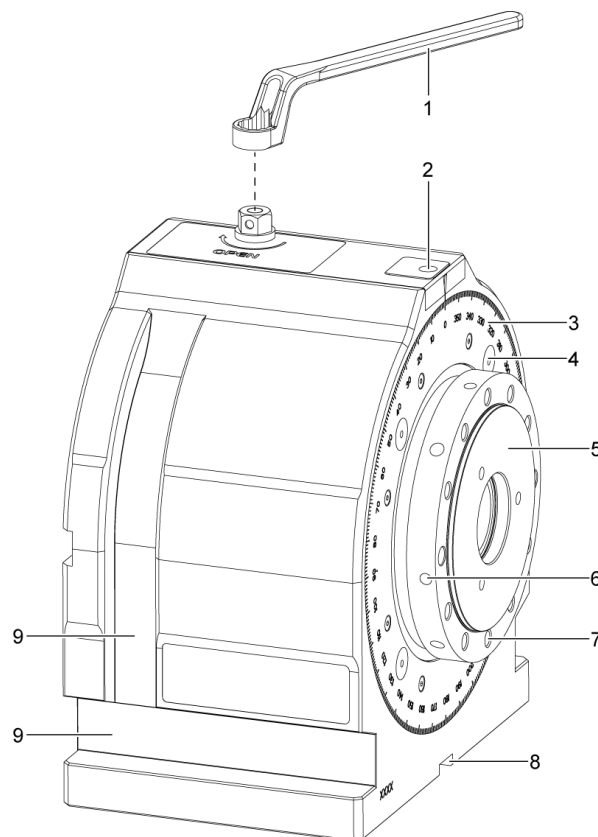

- |                  |                                 |
|------------------|---------------------------------|
| 1 Ring spanner   | 6 Radial holes                  |
| 2 Reference spot | 7 Tapped holes                  |
| 3 Scale          | 8 Shallow slot (alignment slot) |
| 4 Pick-up points | 9 T-slots                       |
| 5 Spindle        |                                 |

## 4 Technical data

<b>Item</b>	<b>Value / range</b>
Length	204.5 mm
Width	260 mm
Height	290 mm
Division	360 x 1°
Standard center height	150 mm
Center height with optional spacers	200 mm or 250 mm
Mounting diameter (cyl.)	Ø = 125 mm -0.005 / -0.015
Locating hole	Ø = 50H6, 10 mm deep
Through hole	Ø = 43 mm
Locking	Positive mechanical locking (automatic)
Indexing accuracy	+ / - 10 seconds
Repeatability	+ / - 4 seconds
Holding torque	2000 Nm
Push-in force of indexing tool	approx. 600 N
Maximum load of indexing tool	1000 N
Weight	42 kg
Minimum increment	1°
Max. working area with one indexing movement	90°
Push-in depth of indexing tool for unlocking	7 mm

## 5 Commissioning



### DANGER



#### **Hazard generated when performing work in the working area of machine tools**

Crushing hazard and hazard generated by drawing in clothes or loose objects during machine axis movements.

This can cause severe injury or death.

→ During work performed in the working area of machine tools, any machine movement that might cause hazards must be avoided.



### DANGER



#### **Hazard generated by the ejection of the device**

The ejection of the device can cause most severe injury or death.

→ Use the fastening set to mount the device safely on the supporting structure.



### WARNING



#### **Hazard generated by open guard doors**

Hazard is generated when a tool is ejected with the guard doors open.

→ Keep the guard doors closed when machining parts under CNC control.



### WARNING



#### **Hazard generated by flying parts**

Parts becoming loose can cause severe injury or death.

→ Make sure workpieces are always safely mounted on the machine.



### WARNING



#### **Hazard generated by ejected components**

The ejection of machine components can cause severe injury or death.

→ Make sure clamping devices and workpieces are always safely mounted on the machine.



### WARNING



#### **Hazard generated by interference with the machine spindle**

Since Rotoklick II is mounted in the working area of the machine, it can interfere with the machine spindle.

→ Always run in NC programs at reduced feedrate.

→ Approach Rotoklick II at reduced feedrate.

→ Avoid interference.



**CAUTION**



**Cutting hazard**

Clamped tools or chips in the working area can cause cuts.

→ Before carrying out any work in the working area, remove any tools or chips.



**CAUTION**



**Hazard generated by improper handling of assembly tools**

Risk of injury is generated when slipping off with the tool during assembly or disassembly work.

→ Use assembly tools carefully to avoid injury.

**NOTE**



**Hazard generated by confined space**

If the device is mounted too close to other components, this can cause people to slip, trip or fall. Moreover, it may become difficult to reach the control points.

→ Arrange the device in a way that safe assembly, operation, disassembly are ensured when using the device for the intended purpose and make sure there is enough space for evasive action.

→ Position the device correctly to ensure unobstructed access to device and workpiece.

## 5.1 Transport



### WARNING



#### **Hazard generated by components**

Falling components due to the use of inappropriate hoists and slings without sufficient load carrying capacity can cause severe injury or death.

- Always use appropriate hoists and slings having sufficient load carrying capacity.
- Observe the correct slinging points and weight specifications.
- Always observe the correct transport velocity.
- Wear protective gloves and protective footwear.

### NOTE



#### **Hazard generated by slings**

When lifting the dividing head and attaching the slings, damage to the dividing head can occur.

- Always use proper slings.
- Be careful when lifting the dividing head.

### 5.1.1 Transport of dividing head

**Required tools / materials:**

- Crane
- Round sling (min. load carrying capacity 50kg)

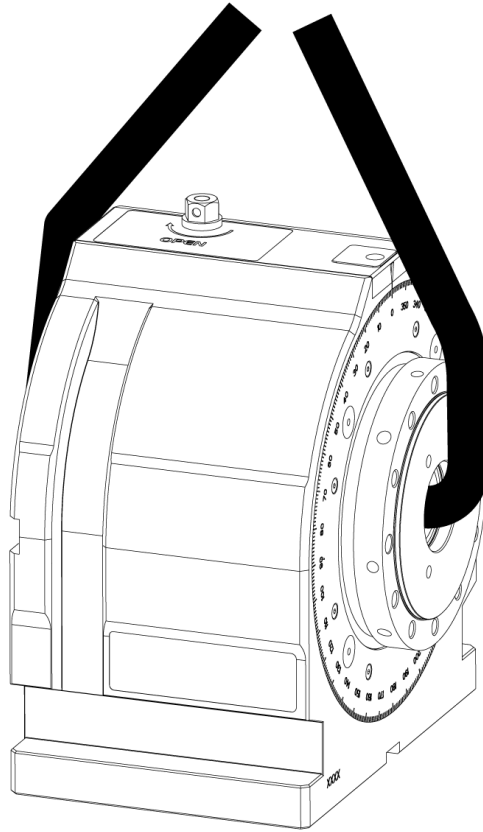

**Procedure:**

- Pull the round sling through the hollow spindle.
- Hook the round sling into a hoist or crane designed for the lifting work to be carried out.
- The dividing head can be moved and lifted onto the machine table.

## 5.1.2 Transport of dividing head including optional equipment

### Required tools / materials:

- Crane
- Round sling (min. load carrying capacity 100kg)
- 4 x eyebolts

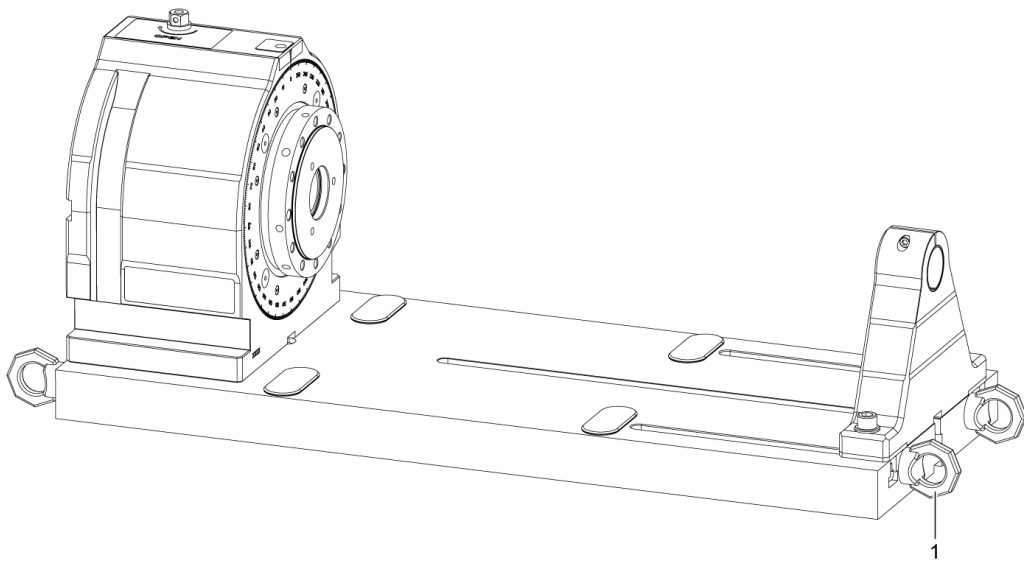

### Procedure:

- Screw the eyebolts (1) into the face of the base plate.
- Pull the round sling / sling chain through the eyelets of the eyebolts.
- Hook the round sling / sling chain into a hoist or crane designed for the lifting work to be carried out.
- Observe the center of gravity and properly balance the dividing head.
- The dividing head can be moved and lifted onto the machine table.

## 5.2 Attachment in the working area

### 5.2.1 Upright attachment

- Clamping directly on the machine table or pallet
- Alignment by means of a sliding block in the 20H7 slot at the bottom side
- Attachment to the provided clamping edge / T-slots on the machine table / pallet by means of clamping jaws

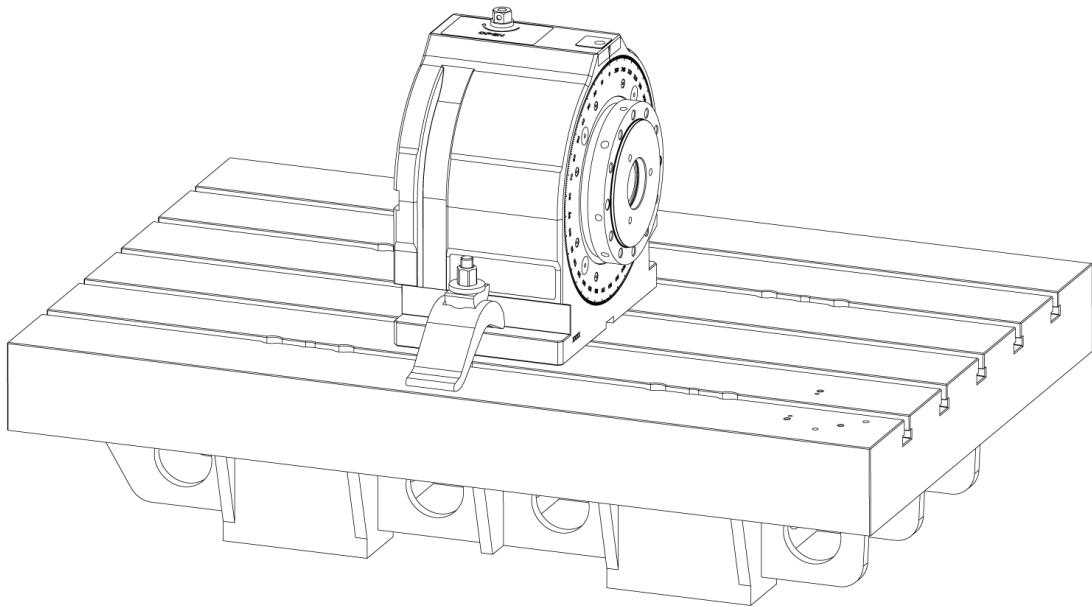

### 5.2.2 Flat attachment

- Clamping directly on the machine table or pallet
- Alignment by means of a sliding block in the 20H7 slot at the bottom side
- Attachment to the provided clamping edge / T-slots on the machine table / pallet by means of clamping jaws

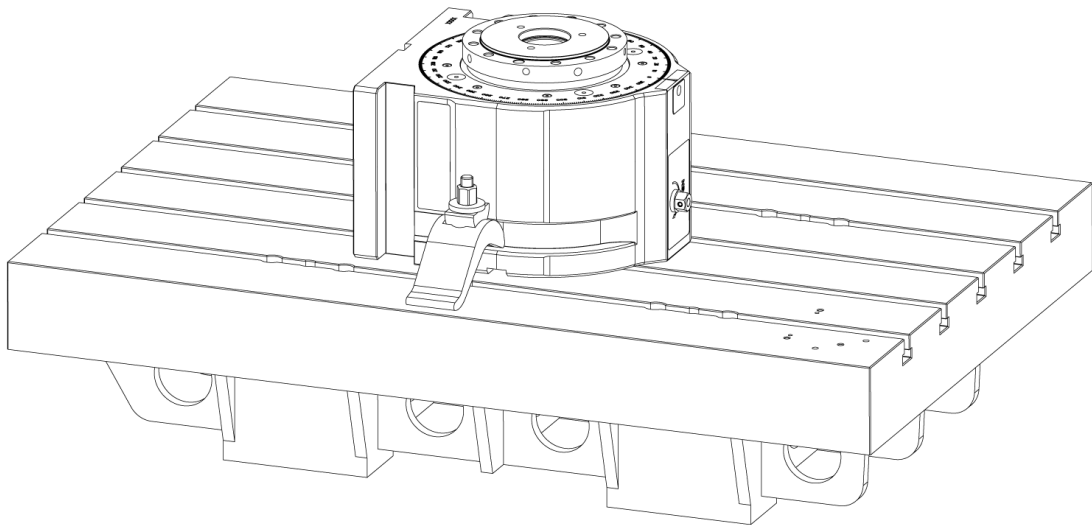

## 6 Manual indexing



### WARNING



#### Crushing hazard

Crushing hazard is generated by moving between two movable components or between one moveable and one stationary component having flat, edgeless surfaces.

- Secure loads with appropriate safeguarding devices.
- The device must be used only by instructed staff.
- Observe the safety instructions in the Operating Instructions.



### WARNING



#### Impact hazard

Impact hazard is generated when a component is moved towards the human body or when the human body is moved towards a stationary component having flat, edgeless surfaces.

- Secure loads with appropriate safeguarding devices.
- The device must be used only by instructed staff.
- Observe the safety instructions in the Operating Instructions.



### WARNING



#### Shearing hazard

During adjustment, shearing and crushing hazard is generated due to eccentric mass distribution (imbalance) of clamping devices around the spindle axis!

- Secure loads with appropriate safeguarding devices.
- The device must be used only by instructed staff.

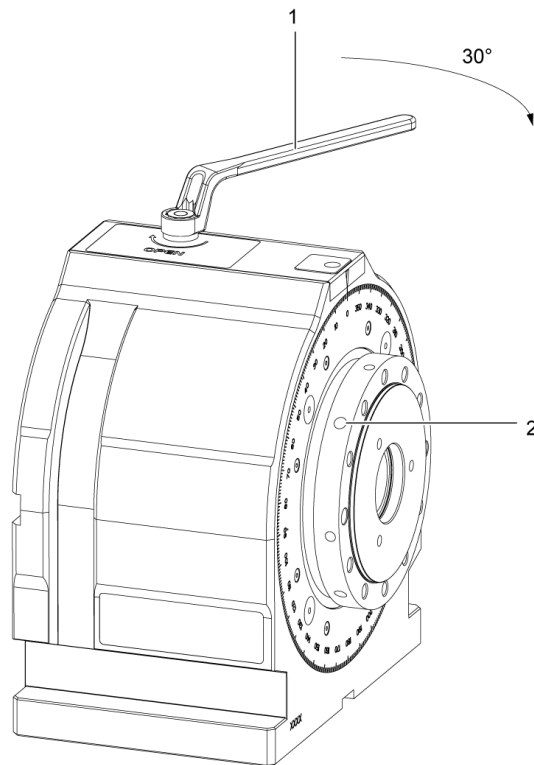

1 Ring spanner

2 Radial holes

**Procedure:**

- Attach the ring spanner to the nut at the top of the dividing head.
- Turn the ring spanner clockwise by approx. 30°.
- The locking mechanism has been released.
- Keep the ring spanner in the unlocking position.
- Carry out the indexing movement up to the desired angular position.
- Return the ring spanner to the original position and remove it.
- Automatic locking is done in accurate 1° increments.



**Information**

A slight resistance is felt in the zero-degree position of Rotoklick II and serves as an aid to orientation.



**Information**

Depending on workpiece size and weight, it may be impossible to rotate the dividing head by mere muscular strength; in such cases, a rod or Allen wrench can be inserted into the radial holes and be used as a lever.

## 7 CNC-controlled indexing



### WARNING



#### Crushing hazard

Crushing hazard is generated by moving between two movable components or between one moveable and one stationary component having flat, edgeless surfaces.

- Secure loads with appropriate safeguarding devices.
- The device must be used only by instructed staff.
- Observe the safety instructions in the Operating Instructions.



### WARNING



#### Impact hazard

Impact hazard is generated when a component is moved towards the human body or when the human body is moved towards a stationary component having flat, edgeless surfaces.

- Secure loads with appropriate safeguarding devices.
- The device must be used only by instructed staff.
- Observe the safety instructions in the Operating Instructions.



### WARNING



#### Shearing hazard

During adjustment, shearing and crushing hazard is generated due to eccentric mass distribution (imbalance) of clamping devices around the spindle axis!

- Secure loads with appropriate safeguarding devices.
- The device must be used only by instructed staff.

### NOTE



#### Hazard generated by the interference with tool and machine tool

Prior to commissioning, the program must be tested to avoid any interference with tool and machine tool.

- The device must be commissioned only by instructed and qualified staff.

### NOTE



#### Notes on programming the feedrate:

- Faults when locking Rotoklick II
- Damage of the indexing tool

Dwell should be used with certain types of control to ensure an accurate push-in movement!



#### Information

Prior to program start, the precise initial position must be checked on the scale and be aligned by hand if necessary.



### Information

The cylindrical shank of the indexing tool fits any tool holder having a diameter of  $D = 20$  mm.

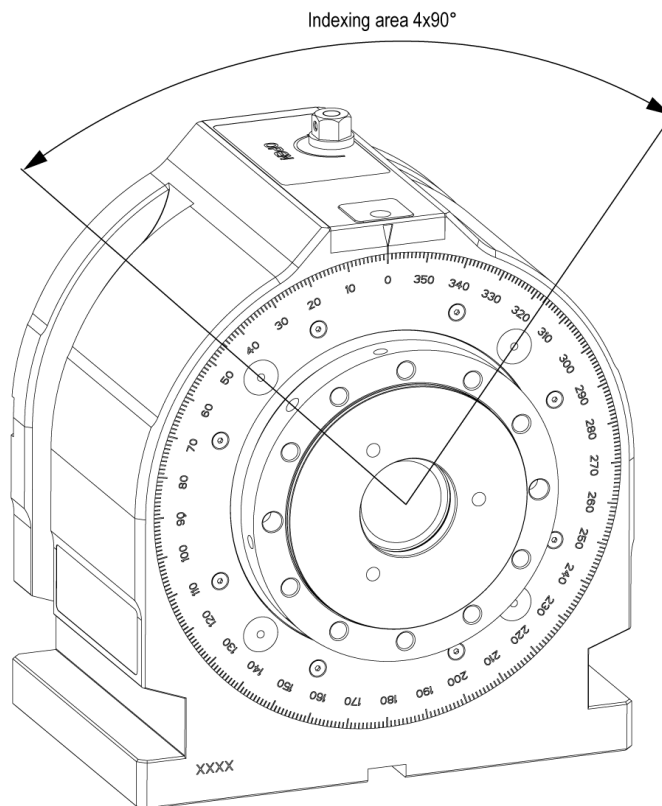

### Description:

During CNC-controlled indexing, the indexing process is carried out with the aid of an indexing tool. During this process, the indexing tool is pushed into the pick-up point and it turns the scale to the desired position at increments of max.  $90^\circ$ . The coordinates can be determined by means of the angle calculator. The latter guarantees fast and correct programming.

## 7.1 Indexing tool



### CAUTION



#### Caution

The tappet of the indexing tool must face the dividing head! (max. angular deviation admitted:  $\pm 3^\circ$ )

#### Larger angular deviations must be compensated for:

- either:  
Compensate by means of spindle orientation of the CNC unit.
- or:  
Turn the indexing tool in the tool holder to the correct position:
  - Loosen the clamping bolt.
  - Turn the indexing tool.
  - Tighten the clamping bolt.
- When doing so:
  - Pay attention to the tool length TL!
  - Re-measure the TL if necessary!

### 7.1.1 Vertical indexing tool

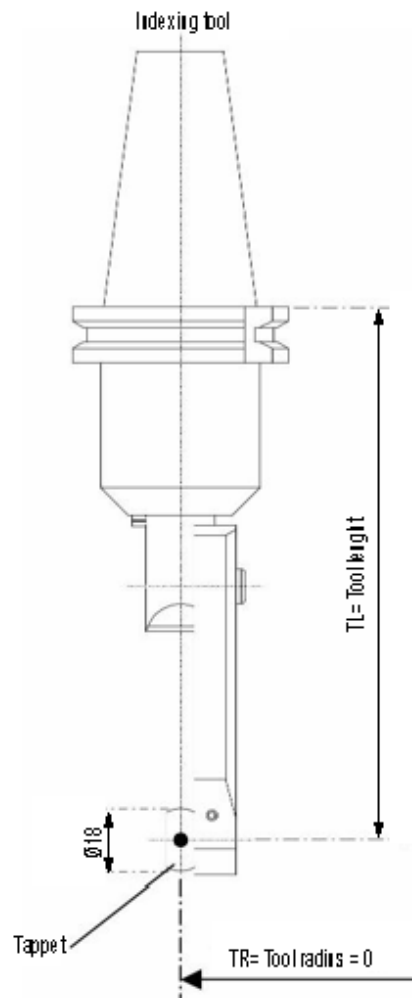

#### Description

The vertical indexing tool is used for machines with vertical spindle. When clamping the indexing tool, its clamping shank must be inserted into the holder until it has contact with the stop and then be tightened with the clamping bolt. Then the tool data must be entered into the control unit. The applicable tool data are: TL = tool length and TR = tool radius = 0.

## 7.1.2 Horizontal indexing tool

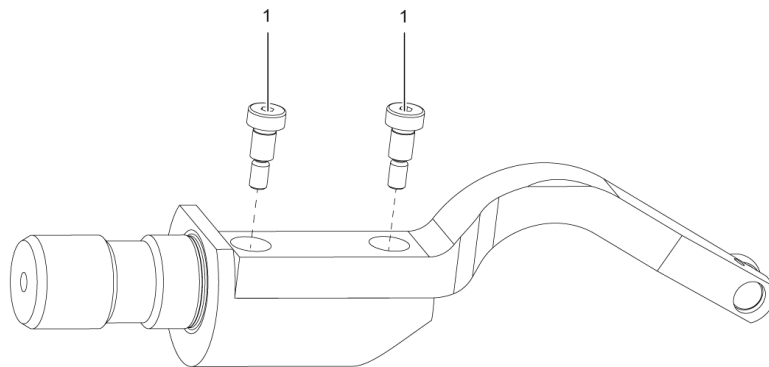

- 1 Locating screw with predetermined breaking point

### Description

The horizontal indexing tool is used for machines with horizontal spindle. For clamping, proceed in the same manner as when clamping the vertical indexing tool. After that, the tool data must be entered into the control unit here as well. Here, the tool length TL also refers to center line of the tappet and the face of the indexing tool.

### 7.1.3 Predetermined breaking point on the indexing tool

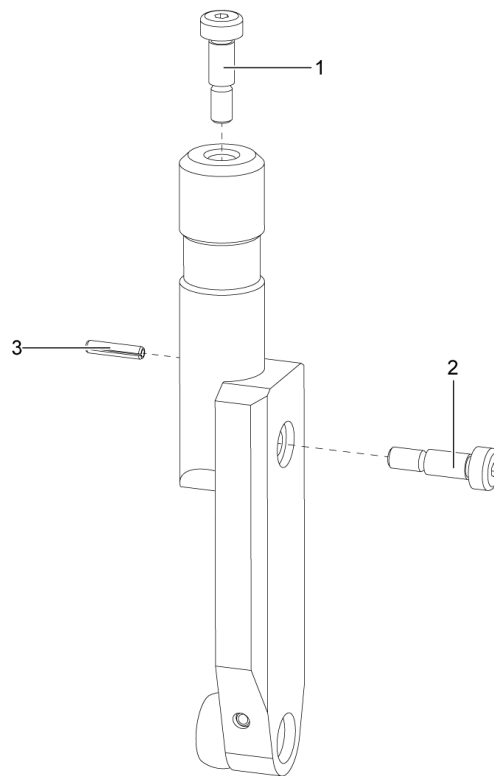

- 1 Replacement screw
- 2 Locating screw with predetermined breaking point

- 3 Dowel pin (stop)

### 7.1.4 Reference point / program zero point for indexing movement

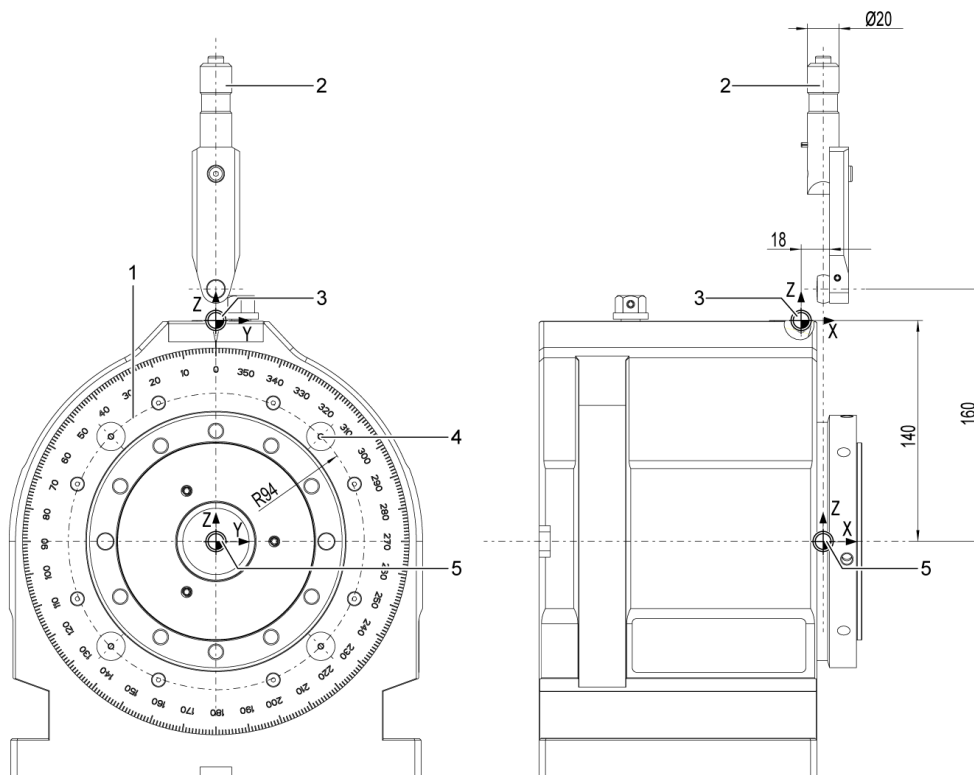

- |   |                 |   |                    |
|---|-----------------|---|--------------------|
| 1 | Dividing circle | 4 | Pick-up 1-4        |
| 2 | Indexing tool   | 5 | Program zero point |
| 3 | Reference point |   |                    |

#### Procedure:

- Enter the indexing tool data into the tool memory (L = tool length TL, R = 0).
- Approach the reference spot with the 3D probe.
- Enter the X0 and Y0 values into the zero point memory.
- Approach the upper edge (reference surface) of the dividing head with the 3D probe.
- Enter the determined Z0 value into the zero point memory.
- Apply the absolute zero offset to the dividing head axis (G93 X18 Y0 Z-140).

### 7.1.5 Approach / unlock

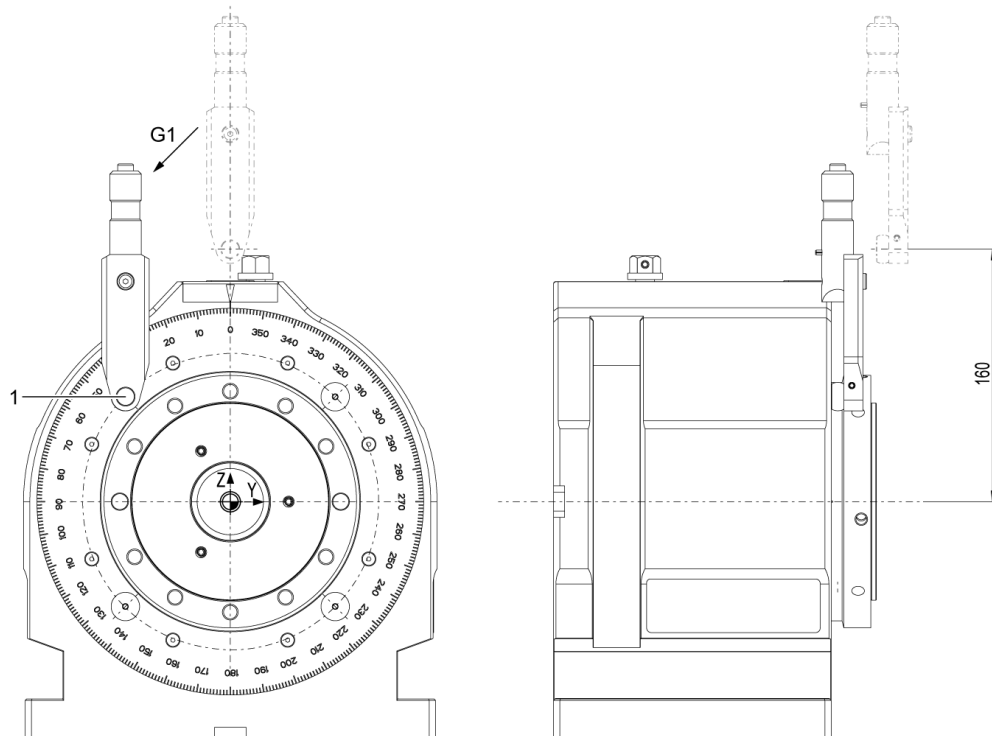

#### Procedure:

- Approach the starting point G0 X0 Y0 Z160.
- Check the position of the 1st pick-up point.
- Check the starting angle on the scale.
- Determine the coordinates by means of the angle calculator and approach them in the Y and Z axes ( $X = 0$ ).
- The indexing tool is pushed in at the pick-up point by the G1 (X-11.5) command.
- The push-in depth of the indexing tool for unlocking is 7 mm.

## 7.1.6 Indexing movement / rotation

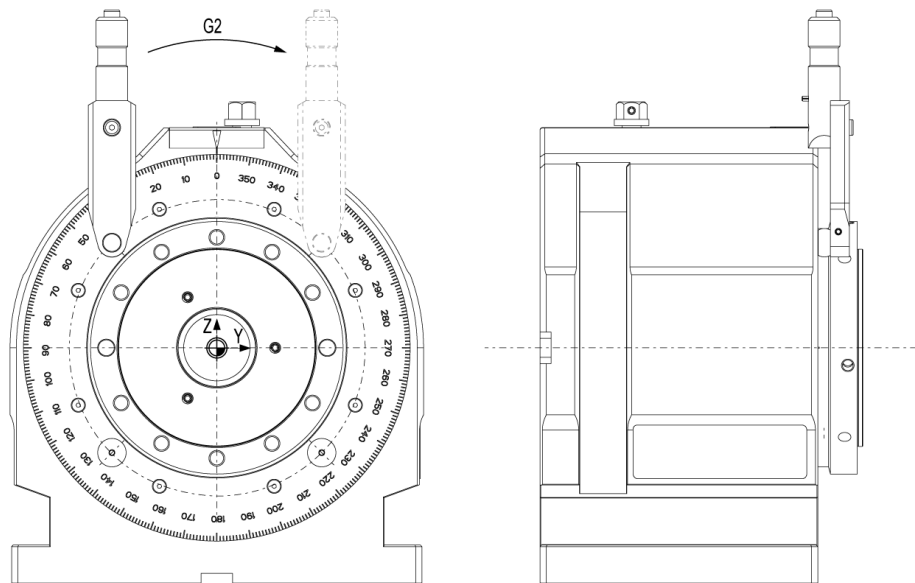

### Procedure:

- For programming a circular movement with the circle center Y0 and Z0, the rotary movement G2 is carried out.
- Determine the coordinates of the pick-up point end position using the angle calculator.
- Enter the coordinates.
- The rotary movement by the desired angular degree is carried out.

### 7.1.7 Lock / retract

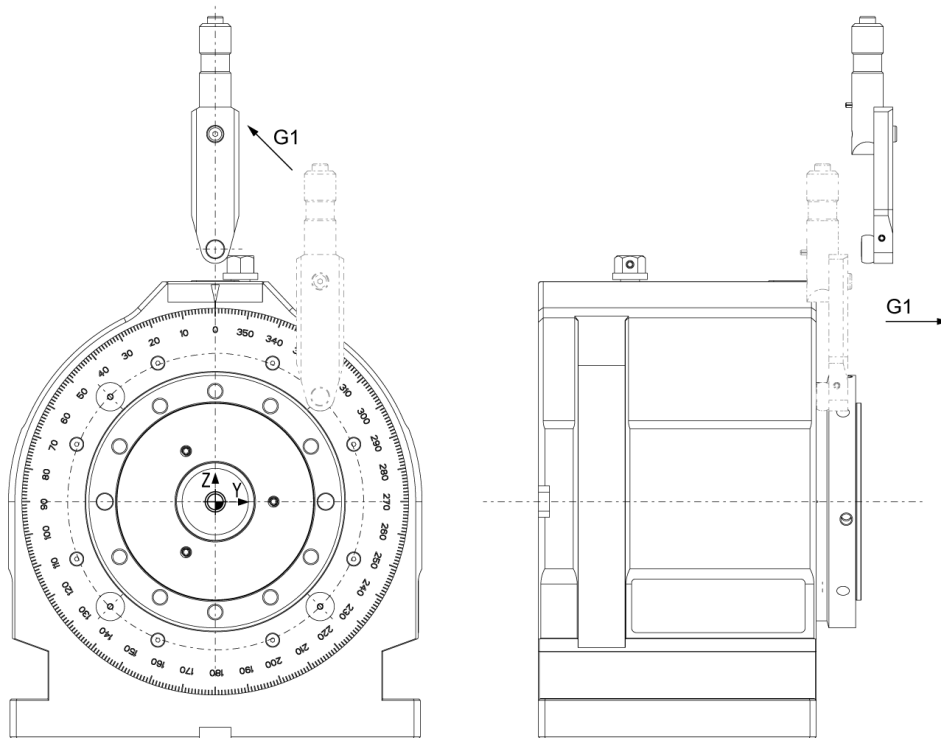

**Procedure:**

- The indexing tool is retracted from the pick-up point.
- Approach the starting point.

## 7.2 Use of the angle calculator



For this product, further information is available. Scan the QR code or visit <https://haff-schneider.com/support/rotoklick-2/angle-calculator/>.

- Scan the QR code.
- The angle calculator opens up.

en | de

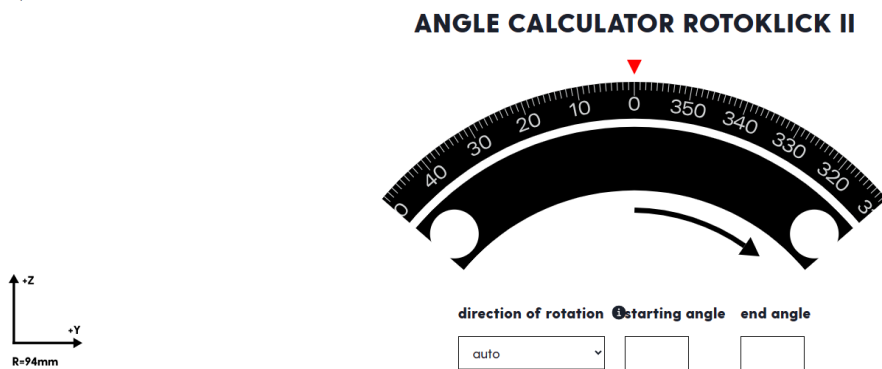

Please enter values!

- Open the dropdown menu in the selection field "direction of rotation" and select the desired mode.  
→ By selecting "auto", the faster path is automatically selected.

en | de

### ANGLE CALCULATOR ROTOKLICK II

The interface features a semi-circular protractor scale with degree markings from 0 to 360. A red triangle points to the 0-degree mark. Below the scale is a coordinate system with a vertical arrow labeled '+Z' and a horizontal arrow labeled '+Y'. The text 'R=94mm' is positioned below the coordinate system. To the right, there are three input fields: a dropdown menu for 'direction of rotation' (currently set to 'auto'), and two empty text boxes for 'starting angle' and 'end angle'. A dropdown menu is open under the 'direction of rotation' field, showing options: 'auto', 'clockwise', and 'counter clockwise'. A curved arrow on the protractor indicates a clockwise rotation direction.

Please enter values!

### 7.2.1 Example 1: Rotary movement from 0° to 90°

- Entry: Starting angle = 0, target angle = 90

en | de

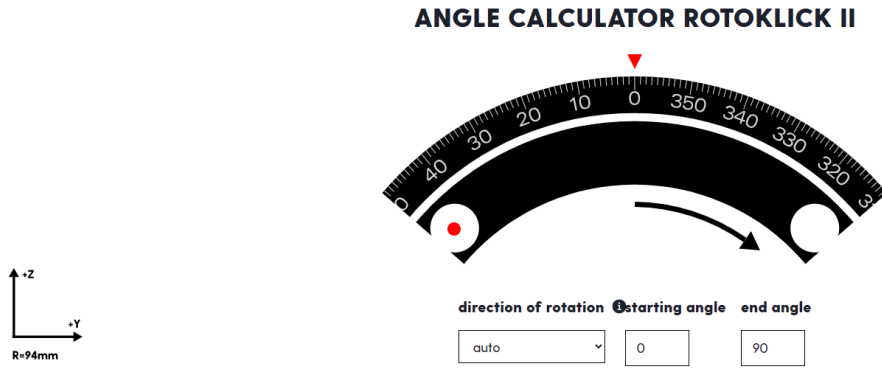

**Step 1**

Pickup Point 45°  
starting coordinates

end coordinates



- Step 1: 1. The pick-up point travels from the starting point coordinates to the end point coordinates.
- Press the ► button.

en | de

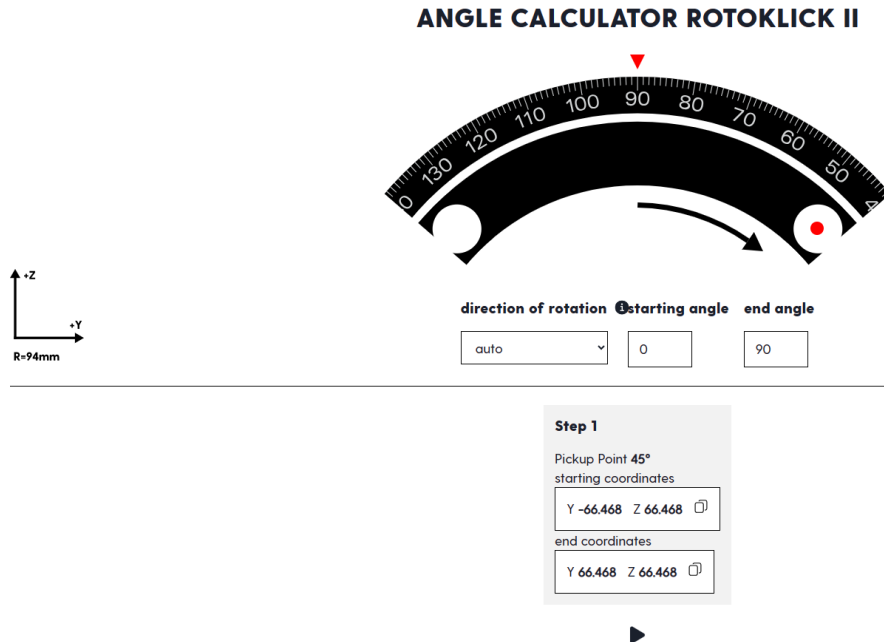

- 1. The pick-up point turns to the end point coordinates.  
→ 90° have been reached.

## 7.2.2 Example 2: Rotary movement from 0° to 120°



### Information

Since the working area is  $\pm 45^\circ$ , any rotary movement exceeding  $90^\circ$  must be carried out in two steps.

- Entry: Starting angle = 0, target angle = 120

en | de

**ANGLE CALCULATOR ROTOKLICK II**

direction of rotation  starting angle  end angle

---

Step 1	Step 2
Pickup Point 45°	Pickup Point 135°
starting coordinates	starting coordinates
<input type="text" value="Y -66.468 Z 66.468"/>	<input type="text" value="Y -66.468 Z 66.468"/>
end coordinates	end coordinates
<input type="text" value="Y 66.468 Z 66.468"/>	<input type="text" value="Y -24.329 Z 90.797"/>

- Step 1: 1. The pick-up point travels from the starting point coordinates to the end point coordinates.
- Press the "rotate" button.

en | de

### ANGLE CALCULATOR ROTOKLICK II

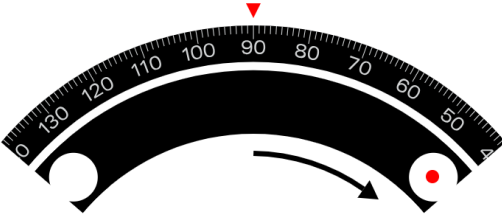

**direction of rotation**  starting angle  end angle

---

Step 1	Step 2
Pickup Point 45°	Pickup Point 135°
starting coordinates	starting coordinates
<input type="text" value="Y -66.468 Z 66.468"/>	<input type="text" value="Y -66.468 Z 66.468"/>
end coordinates	end coordinates
<input type="text" value="Y 66.468 Z 66.468"/>	<input type="text" value="Y -24.329 Z 90.797"/>

- 1. The pick-up point turns to the end point coordinates.
- Press the "next step" button.
- 2. The pick-up point is selected.

en | de

### ANGLE CALCULATOR ROTOKLICK II

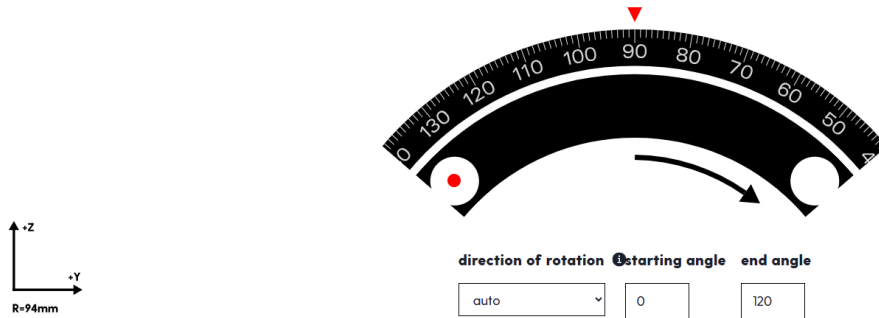

#### Step 1

Pickup Point 45°

starting coordinates

Y -66.468 Z 66.468

end coordinates

Y 66.468 Z 66.468

#### Step 2

Pickup Point 135°

starting coordinates

Y -66.468 Z 66.468

end coordinates

Y -24.329 Z 90.797

◀ previous step

▶ rotate

- Press the "rotate" button.
- 2. The pick-up point turns from the starting point coordinates to the end point coordinates.

en | de

### ANGLE CALCULATOR ROTOKLICK II

direction of rotation  starting angle  end angle

direction of rotation: auto

**Step 1**  
Pickup Point 45°  
starting coordinates: Y -66.468 Z 66.468  
end coordinates: Y 66.468 Z 66.468

**Step 2**  
Pickup Point 135°  
starting coordinates: Y -66.468 Z 66.468  
end coordinates: Y -24.329 Z 90.797

◀ previous step    ▶ rotate

→120° have been reached.

## 7.3 Programming examples

### 7.3.1 Programming examples for DIN-type control units

For instance, for **DIN-type control units**, an indexing movement from 0° to 90° (dividing head scale) corresponds to an indexing movement of the pick-up point from 135° to 45°.

For the coordinate values, refer to the angle calculator.



#### CAUTION



#### Caution

Check the machine's coordinate system!



#### Information

The recommended feedrate for the push-in movement is 1 m/min. The recommended feedrate for the indexing movement is 1 – 3 m/min. The feedrate always depends on the machine type and the moving mass.

The G52 zero point is the reference zero point (refer to the angle calculator).

%PM	Meaning
N9000	(Rotate Rotoklick II from 0° to 90°)
N10 G17	(Enable G17 plane)
N11 G52	(Zero offset to the reference zero point)
N12 F1000 S0 T98 M6	(Load indexing tool)
N13 D90 M19	Spindle position
N14 G22 N=9101	(Call macro indexing movement)
N15 M30	

%MM	Meaning
N9101	(Macro indexing movement)
N10 G93 X18 Y0 Z-140	(Abs. zero offset to the Rotoklick II axis)
N11 G0 X0 Y0 Z160	(Starting position above Rotoklick II)
N12 G1 Y-66.468 Z66.468	(Approach pick-up point 1)
N14 G1 X-11.5	(Push-in / unlock)
N15 G2 Y66.468 Z66.468 J0 K0	(Rotate from 0° to 90°)
N16 G1 X0	(Retract, lock)
N17 G1 Y0 Z160	(End position above Rotoklick II)

### 7.3.2 Programming example for Heidenhain TNC 355

For the **Heidenhain TNC 355 control unit**, an indexing movement from 0° to 90° (dividing head scale) corresponds to an indexing movement of the pick-up point from 135° to 45°.

For the coordinate values, refer to the angle calculator.



#### CAUTION



#### Caution

Check the machine's coordinate system!



#### Information

The recommended feedrate for the push-in movement is 1 m/min. The recommended feedrate for the indexing movement is 1 – 3 m/min. The feedrate always depends on the machine type and the moving mass.

The zero point is the reference zero point (refer to the angle calculator).

0	BEGIN PGM 2802961 MM	(Rotate Rotoklick II from 0° to 90°)
1	TOOL CALL 90 Z S 0.00	(Tool length in tool memory)
2		Spindle stop position
3	CYCL DEF 7.0 NULLPUNKT	(Zero offset in Rotoklick II axis)
4	CYCL DEF 7.1 X-18.000	
5	CYCL DEF 7.2 Y-0.000	
6	CYCL DEF 7.3 Z-140.000	
7	L X+0.000 Y+0.000 R0 F9999 M L Z+160.000 R0 F9999 M	(Starting position above Rotoklick II)
8	L Y-66.468 Z+66.468 R F2000 M	(Approach pick-up point 1)
9	L X-11.500 R F M	(Push-in / unlock)
10	CC Y+0.000 Z+0.000	(Define circle center)
11	CP IPA+90.000 DR- R F M	(Indexing movement with angle specification)
12	L X+0.000 R F M	(Retract, lock)
13	L Y+0.000 Z+160.000 R F M30	(End position above Rotoklick II)
14	END PGM 2802961 MM	

### 7.3.3 Programming example for Heidenhain TNC 640

For the **Heidenhain TNC 640 control unit**, an indexing movement from 0° to 90° (dividing head scale) corresponds to an indexing movement of the pick-up point from 135° to 45°.

For the coordinate values, refer to the angle calculator.



#### CAUTION



#### Caution

Check the machine's coordinate system!



#### Information

The recommended feedrate for the push-in movement is 1 m/min. The recommended feedrate for the indexing movement is 1 – 3 m/min. The feedrate always depends on the machine type and the moving mass.

The zero point is the reference zero point (refer to the angle calculator).

0	BEGIN PGM 2802961 MM	
1	TOOL CALL 90 Z S 0.00	(Tool length in tool memory)
2		Spindle stop position
3	CYCL DEF 7.0 NULLPUNKT	(Zero offset in Rotoklick II axis)
4	CYCL DEF 7.1 X-18.000	
5	CYCL DEF 7.2 Y+0.000	
6	CYCL DEF 7.3 Z-140.000	
7	L X+0.000 Y+0.000 R0 F9999	
8	L Z+160.000 R0 F9999	
9		(Starting position above Rotoklick II)
10	L Y-66.468 Z+66.468 R0 F2000	(Approach pick-up point 1)
11	L X-11.500	(Push-in / unlock)
12	CC Y+0.000 Z+0.000	(Define circle center)
13	CP IPA+90.000 DR-	(Indexing movement with angle specification)
14	L X+0.000	(Retract, lock)
15	L Y+0.000 Z+160.000	(End position above Rotoklick II)
16	M30	
17	END PGM 2802961 MM	

## 8 Optional equipment



### WARNING



#### Crushing hazard

Crushing hazard is generated by moving between two movable components or between one moveable and one stationary component having flat, edgeless surfaces.

- Secure loads with appropriate safeguarding devices.
- The device must be used only by instructed staff.
- Observe the safety instructions in the Operating Instructions.



### WARNING



#### Impact hazard

Impact hazard is generated when a component is moved towards the human body or when the human body is moved towards a stationary component having flat, edgeless surfaces.

- Secure loads with appropriate safeguarding devices.
- The device must be used only by instructed staff.
- Observe the safety instructions in the Operating Instructions.



### WARNING



#### Shearing hazard

During adjustment, shearing and crushing hazard is generated due to eccentric mass distribution (imbalance) of clamping devices around the spindle axis!

- Secure loads with appropriate safeguarding devices.
- The device must be used only by instructed staff.

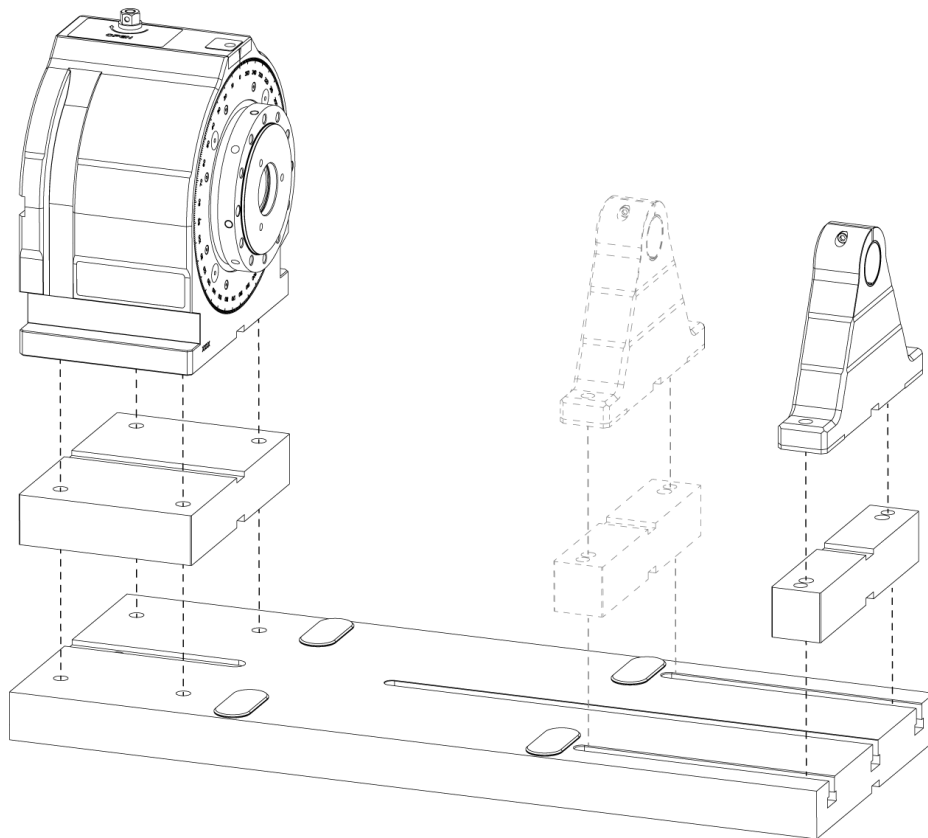

Rotoklick II can be expanded by additional optional equipment (e.g. lathe chuck, rocker, cube or traverse).

Tailstocks or counter holders are used to support large workpieces. Furthermore, the counter holder prevents any bending of rocker, cube or traverse during the machining of large workpieces.

When selecting the optional equipment with counter holder or tailstock, additional base plate and spacers can be provided.

## 8.1 Wedge-shaped clamping elements for radial flange connection

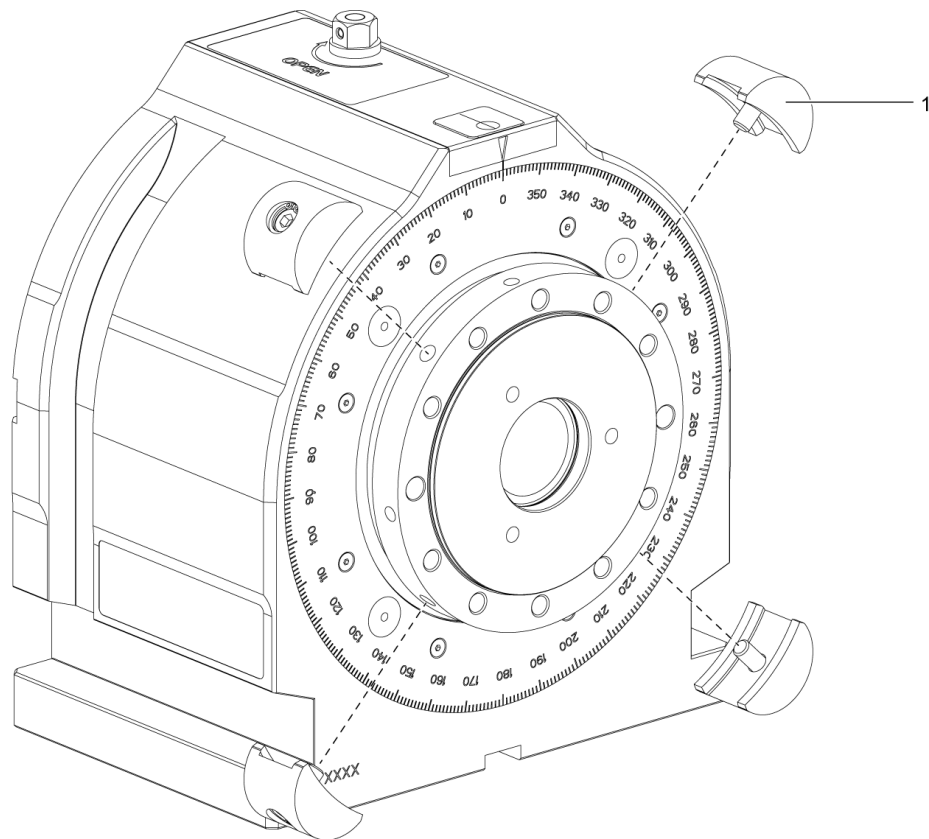

1 Wedge-shaped clamping elements (4x)

### Description

These wedge-shaped clamping elements enable various attachments to be mounted to Rotoklick II without any major effort.

## 8.2 Lathe chuck

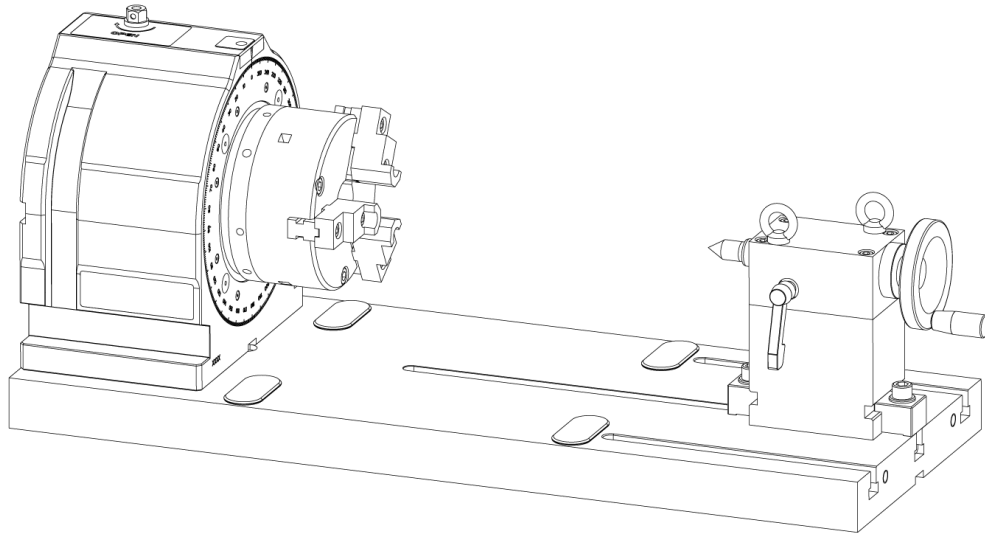

### Description

The lathe chuck can be used with or without tailstock or counter holder. The jaw chuck enables all-around machining of round workpieces. Thanks to a hollow spindle, bars up to a diameter of D40 can be machined.

## 8.3 Rocker

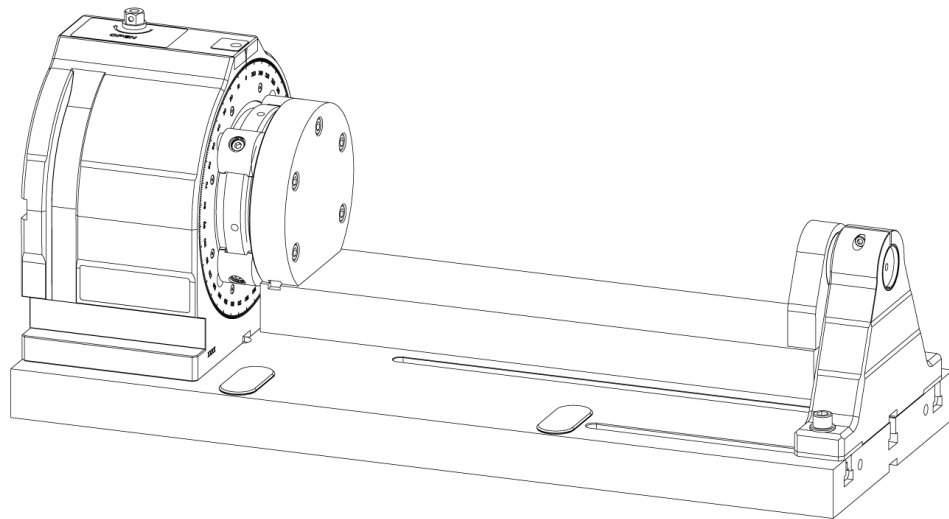

### Description

The rocker features an asymmetrical design. High rigidity is achieved when the workpiece is machined near the center. The workpiece is closer to the center of the interference circle, so larger workpieces can be machined.

## 8.4 Traverse

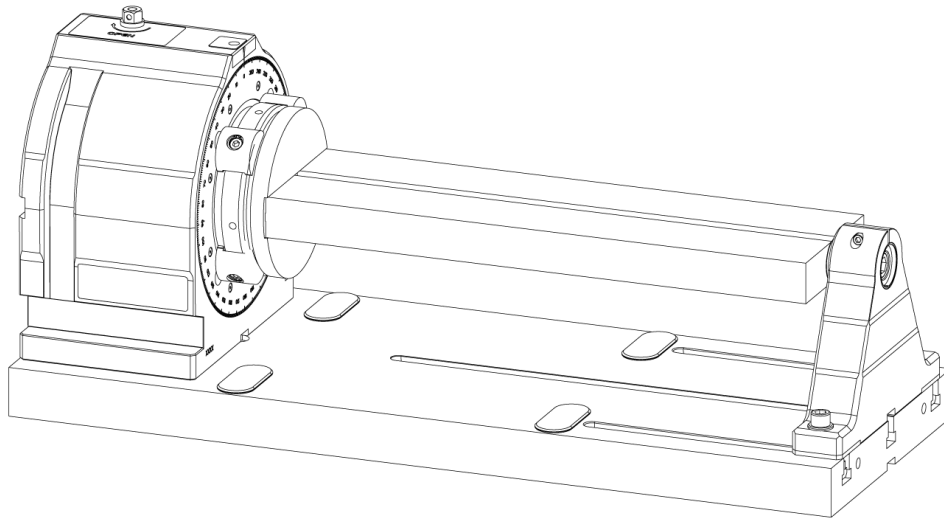

### Description

The traverse enables positioning of workpiece and clamping device on both sides. Multiple clampings are thus possible.

## 8.5 Cube

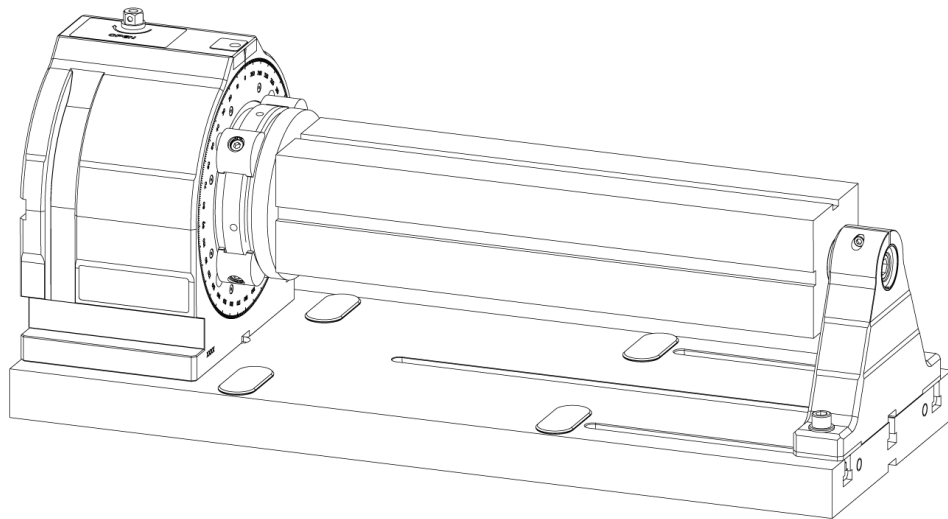

### Description

The cube enables positioning of workpiece and clamping device on all four sides. Multiple clampings are thus possible.

## 9 Maintenance



### DANGER



#### **Hazard generated when performing work in the working area of machine tools**

Crushing hazard and hazard generated by drawing in clothes or loose objects during machine axis movements.

This can cause severe injury or death.

→ During work performed in the working area of machine tools, any machine movement that might cause hazards must be avoided.



### CAUTION



#### **Cutting hazard**

Clamped tools or chips in the working area can cause cuts.

→ Before carrying out any work in the working area, remove any tools or chips.



### CAUTION



#### **Hazard generated by a leaking device**

Leaking grease can cause slipping hazard, irritation of the respiratory system as well as skin and eye irritation.

→ Do not use a leaking device and remedy any defects.

→ The device must not be re-used until it has been repaired appropriately.

→ In case of contact with grease, wear appropriate protective clothing (gloves, goggles and working clothing).

→ Wipe off grease with appropriate means.



### CAUTION



#### **Hazard generated by maintenance work**

Hazard is generated by the device during maintenance, repair or cleaning work.

→ The device must be repaired only by instructed staff.



### NOTE

#### **Hazard generated by contamination**

Contamination in the surrounding area of the device can cause malfunction and further hazards.

→ Clean the device and its surrounding area at regular intervals.



#### **Information**

In case of malfunction, please contact your distributor.



#### **Information**

In case of mechanical damage, please contact the manufacturer.

## 9.1 Warranty

The assertion of warranty claims assumes that the product has been used according to contract and that the maintenance and repair work specified by the manufacturer has been carried out in accordance with the Operating Instructions.

## 9.2 Maintenance



### Information

- The device is absolutely maintenance-free!
- No re-greasing necessary!

The exposure to coolant, water, dust or oil during operation does not have any adverse effects on Rotoklick II. In order to grant a long service life of the device, however, we recommend to wipe off any contamination with a cloth lightly dampened with neutral solvent. Volatile organic solvents like thinner should be avoided as these liquids may damage the housing.

All substances and materials used must be handled properly and disposed of in accordance with the environmental regulations, in particular

- when working with lubricants and
- when cleaning using solvents.



### Information

In case of mechanical damage, please contact the manufacturer.

## 9.3 Inspection

Inspection works	Prior to commissioning	Qualification level
Visual inspection for external damage of the housing	x	1

## **10 Decommissioning, storage, disposal**

Decommissioning, storage and disposal rank among the work to be carried out very rarely.

### **10.1 Decommissioning**

- Clean thoroughly

### **10.2 Storage**

During storage of Rotoklick II, care must be taken not to damage the housing. Furthermore, Rotoklick II should be covered with a hood to avoid contact with loose dust or soil.

### **10.3 Disposal**

All local regulations for proper disposal, environmental compatibility and the avoidance of health risks shall be complied with. For detailed information, please contact the Department responsible for Waste Management.

Metals, non-metals, composites and auxiliary materials must be separated by type and disposed of in an environmentally friendly manner.

# 11 Annex

## 11.1 List of part numbers

Description	Part number
Rotoklick II	149498
Vertical indexing tool	71-05230
Horizontal indexing tool	71-05230-02
Spacer set	71-05560-49
Base plate set, universal	71-05520-49
Base plate set, custom-made	152475-00
Fastening set for base plate, 14mm	71-05540-14
Fastening set for base plate, 16mm	71-05540-16
Fastening set for base plate, 18 mm	71-05540-18
Three-jaw chuck	47-00370
Top jaw set for three-jaw chuck	103153
Four-jaw chuck	47-00371
Top jaw set for four-jaw chuck	103152
Raw flange	71-05650-49
Rocker set	71-05610-02
Traverse set	71-06680-02
Clamping cube set	71-06690-02
Counter holder set XTURN	144104
Tailstock (stroke = 25 mm) incl. fastening set, 14 mm	117016
Fastening set for tailstock	117019
Live center	47-00786
Wedge-shaped clamping elements for radial flange connection	71-05770

## 11.2 EU Declaration of Conformity

### Konformitätserklärung gemäß EG - Maschinenrichtlinie (2006/42/EG, Anh. II 1. A)

-Original-

Der Hersteller,

Haff & Schneider GmbH & Co. OHG  
Richard Schneider  
Obere Wank 2  
87484 Nesselwang



erklärt in alleiniger Verantwortung, dass die Auswechselbare Ausrüstung,

Bezeichnung: Teilapparat mechanisch  
Model: Rotoklick II  
Type: 150  
Identifikationsnummer: Rotoklick II 149498  
Seriennummer: 0001 bis 9999  
Baujahr: 2023

allen einschlägigen Bestimmungen der Richtlinie 2006/42/EG - Maschinenrichtlinie entspricht.

Folgende harmonisierte Normen wurden angewandt:

Norm	Titel
EN ISO 12100:2010	Sicherheit von Maschinen — Allgemeine Gestaltungsleitsätze — Risikobeurteilung und Risikominderung (ISO 12100:2010)
EN 1550:1997+A1:2008	Sicherheit von Werkzeugmaschinen - Sicherheitsanforderungen für die Gestaltung und Konstruktion von Spannfuttern für die Werkstückaufnahme

Für die Zusammenstellung der technischen Unterlagen ist beauftragt: Richard Schneider

Unterzeichner und Angaben zum Unterzeichner: Richard Schneider (Geschäftsführer)

Ort, Datum: Nesselwang, 12.12.2023

Unterschrift: ..........

# 11.3 Rotoklick II - Dimension sheet

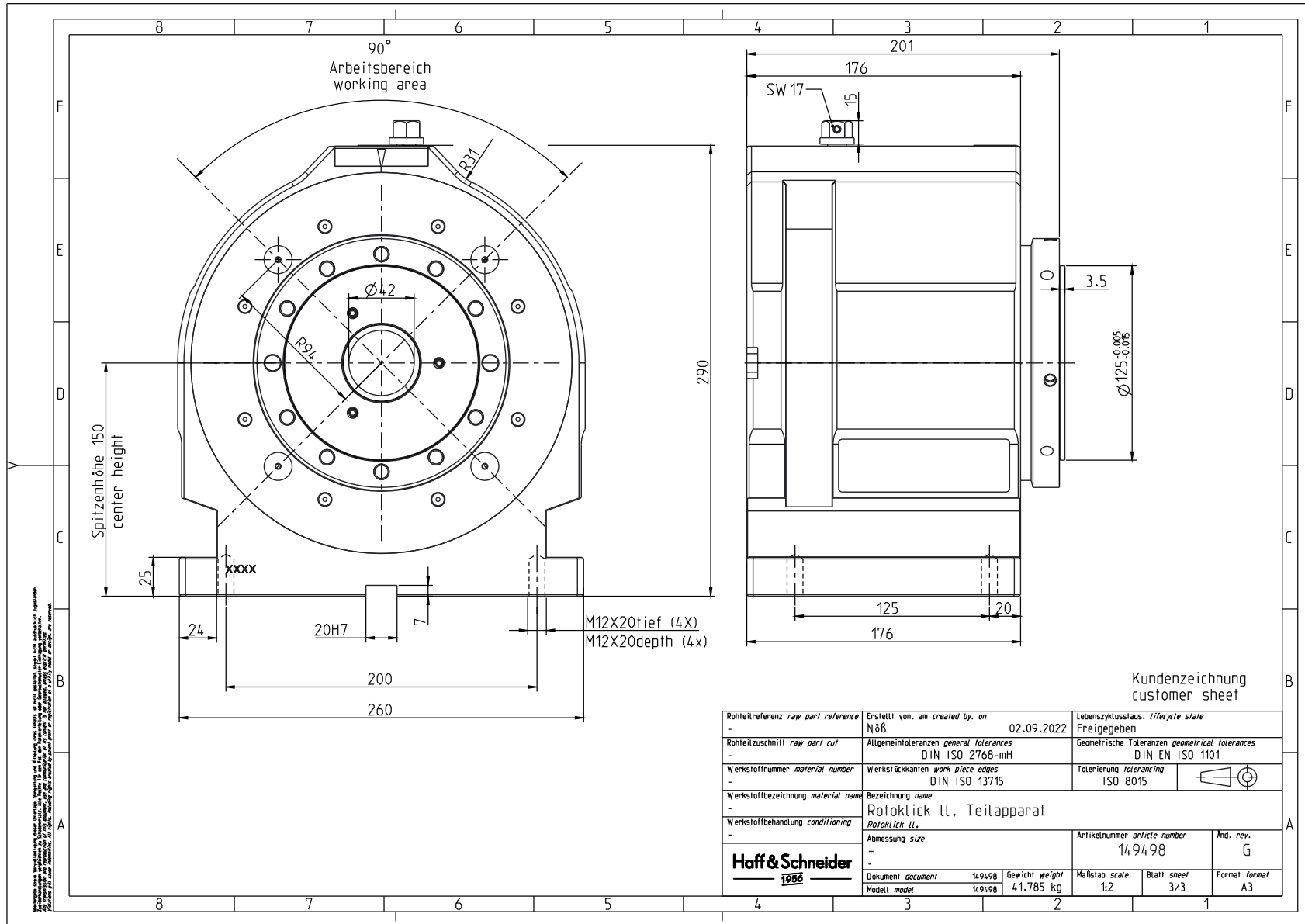

# 11.4 Rotoklick II - Component overview

Pos	Modell model	Artikel article number	Bezeichnung	name
24	120712-00	120712-00	Distanzplatten-Set f. Gegenhalter	Spacer plates-Set f. Rotoklick Mk150 shaft support
23	103026	71-05230-02	Taktwerkzeug horizontal (für linke Seite)	Indexing tool horizontal (sickle on the left)
22	107511	107511	Taktwerkzeug rund f. HURCO	Indexing tool spherical for Hurco
21	152475-00	152475-00	Grundplatten-Set nach Kundenwunsch	base plate-Set according to the customers' request
20	103081	71-05770	radiale Flanschbindung Schnittstelle Spindel-Flansch	Axial/radial wedge-shaped clamping elements col.
19	103155	47-00786	mitlaufende Drehbankspitze MK2	Revolving lathe center MK2
18	117019	117019	Befestigungsset Reitstock für Maschinentisch	Fastening-Set tailstock for machine table
17	117016	117016	Reitstock kpl. Hub=25 mit Befestigungsset 14mm	Tailstock-Set complete incl. fastening-Set 14mm
16	144104	144104	Gegenhalter-Set XTURN GH50	Shaft support complete GH50
15	103042	71-06690-02	Spannwürfel-Set MK150	Cube complete MK150
14	103045	71-06680-02	Traverse-Set MK150	Crossbeam complete MK150
13	103051	71-05610-02	Tilge-Set MK150	Tilting table complete MK150
12	103037	71-05650-49	Rohflansch kpl. MK150	Raw flange complete MK150
11	103152	103152	Aufsatzbacken-Set inkl. Schrauben f. Vierbackenfutter D160	Soft top jaw-Set incl. screws for four jaw chuck D160
10	103151	47-00371	Vierbackenfutter kpl. inkl. Schrauben, Typ 803	Four-jaw chuck complete incl. screws, type 803
9	103153	103153	Aufsatzbacken-Set inkl. Schrauben f. Dreibackenfutter D160	Soft top jaw-Set incl. screws for three jaw chuck D160
8	103150	47-00370	Dreibackenfutter kpl. inkl. Schrauben, Typ 603	Three-jaw chuck complete incl. screws, type 603
7	103075	71-05540-18	Befestigungsset Grundplatte für Maschinentische	Fastening-Set base plate for machine table
6	103074	71-05540-16	Befestigungsset Grundplatte für Maschinentische	Fastening-Set base plate for machine table
5	103073	71-05540-14	Befestigungsset Grundplatte für Maschinentische	Fastening-Set base plate for machine table
4	103071	71-05520-49	Mk150 Grundplatten-Set (universell)	Mk150 base plate-Set (universal)
3	120711-00	120711-00	Distanzplatten-Set f. Rotoklick Mk150	Spacer plates-Set f. Rotoklick Mk150 shaft support
2	103018	71-05230	Taktwerkzeug vertikal	Indexing tool vertical vertical
1	149498	149498	Rotoklick II Teilapparat	Rotoklick II

Rohteilreferenz raw part reference	Erstellt von, an created by, on		Lebenszyklus, lifecycle state		
-	N 85		24.01.2023		
Freigegeben					
Rohteilzeichnung raw part col	Allgemeintoleranzen general tolerances				
-	DIN ISO 2768-mH				
Werkstoffnummer material number	Werkstückkanten work piece edges		Geometrische Toleranzen geometrical tolerances		
-	DIN ISO 13715		ISO 8015		
Werkstoffbezeichnung material name	Tolerierung tolerancing				
-	ISO 8015				
Werkstoffbehandlung conditioning	Bezeichnung name				
-	Komponentenübersicht, Rotoklick II				
-	Survey of standard components, rotoklick II		Messung size		
-	-		Artikelnummer article number		
-	-		150554		
-	-		Ind. rev. D		
Hoff & Schneider		95954 Gewicht weight		Maßstab scale	
1968		224.576 kg		Blatt sheet	
-		95954		1:5	
-		-		Format format	
-		-		A2	

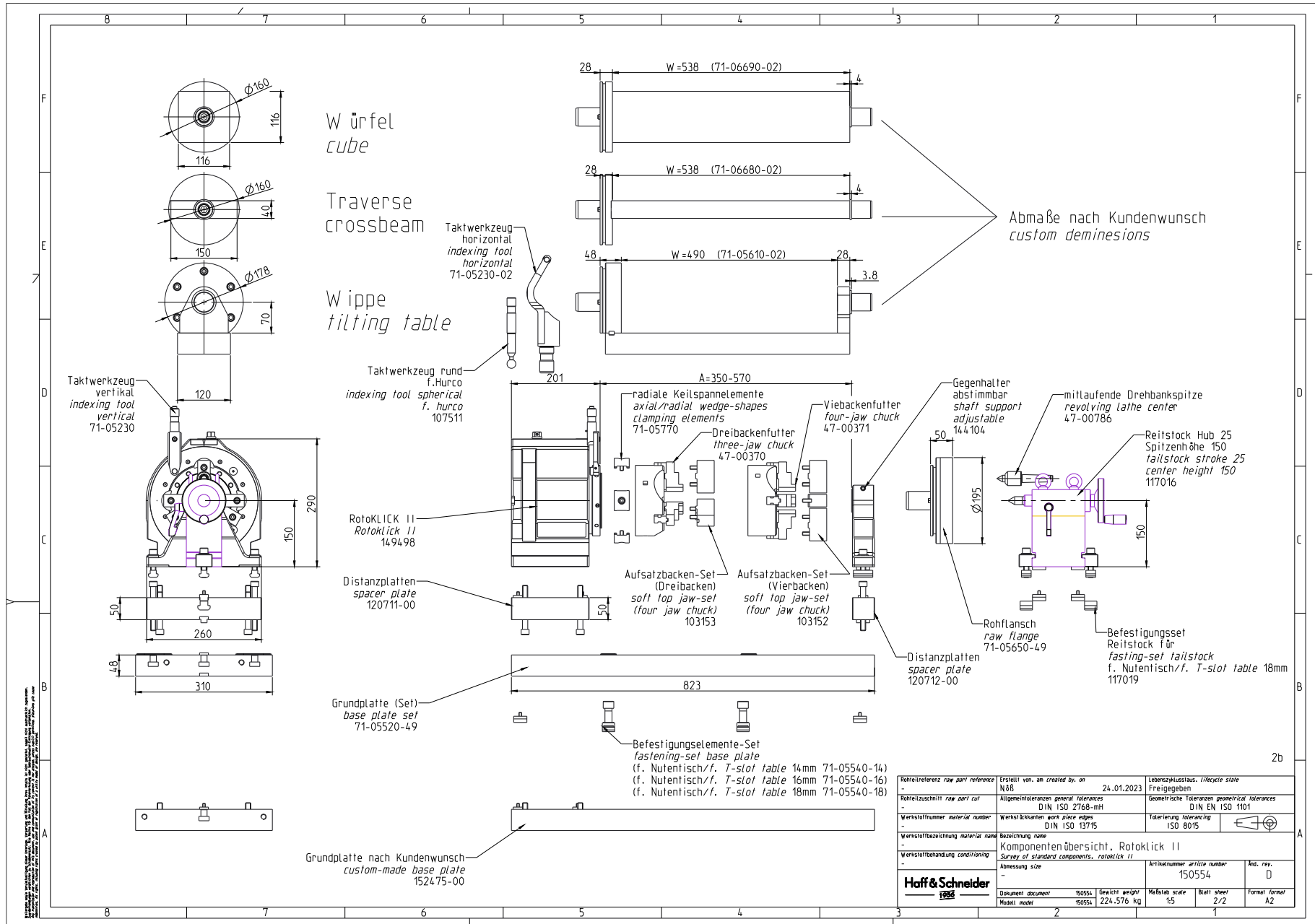

Hoff & Schneider  
 1988  
 150554  
 224.576 kg  
 1:5  
 2/2  
 A2

Rohteilreferenz raw part reference	Erstellt von, an created by, on	NöB	24.01.2023	Lebenszyklusstaus, if/except state Freigegeben
Rohteilzeichnung raw part cut	Allgemeintoleranzen general tolerances	Geometrische Toleranzen geometrical tolerances		
Werkstoffnummer material number	Werkstückkanten work piece edges	DIN ISO 2768-mH	DIN EN ISO 1101	
Werkstoffbezeichnung material name	Werkstoffbehandlung conditioning	DIN ISO 13715	Tolerierung tolerancing	ISO 8015
Bezeichnung name Komponentenübersicht, Rotoklick II				
Survey of standard components, rotoklick II				
Abmessung size	Artikelnummer article number	150554		Änd. rev. D
Hoff & Schneider 1988		Dokument document	150554	Gewicht weight 224.576 kg
Modell model	150554	Maßstab scale	1:5	Blatt sheet 2/2
				Format format A2

2b